

Technical details

Deco & Ellipse

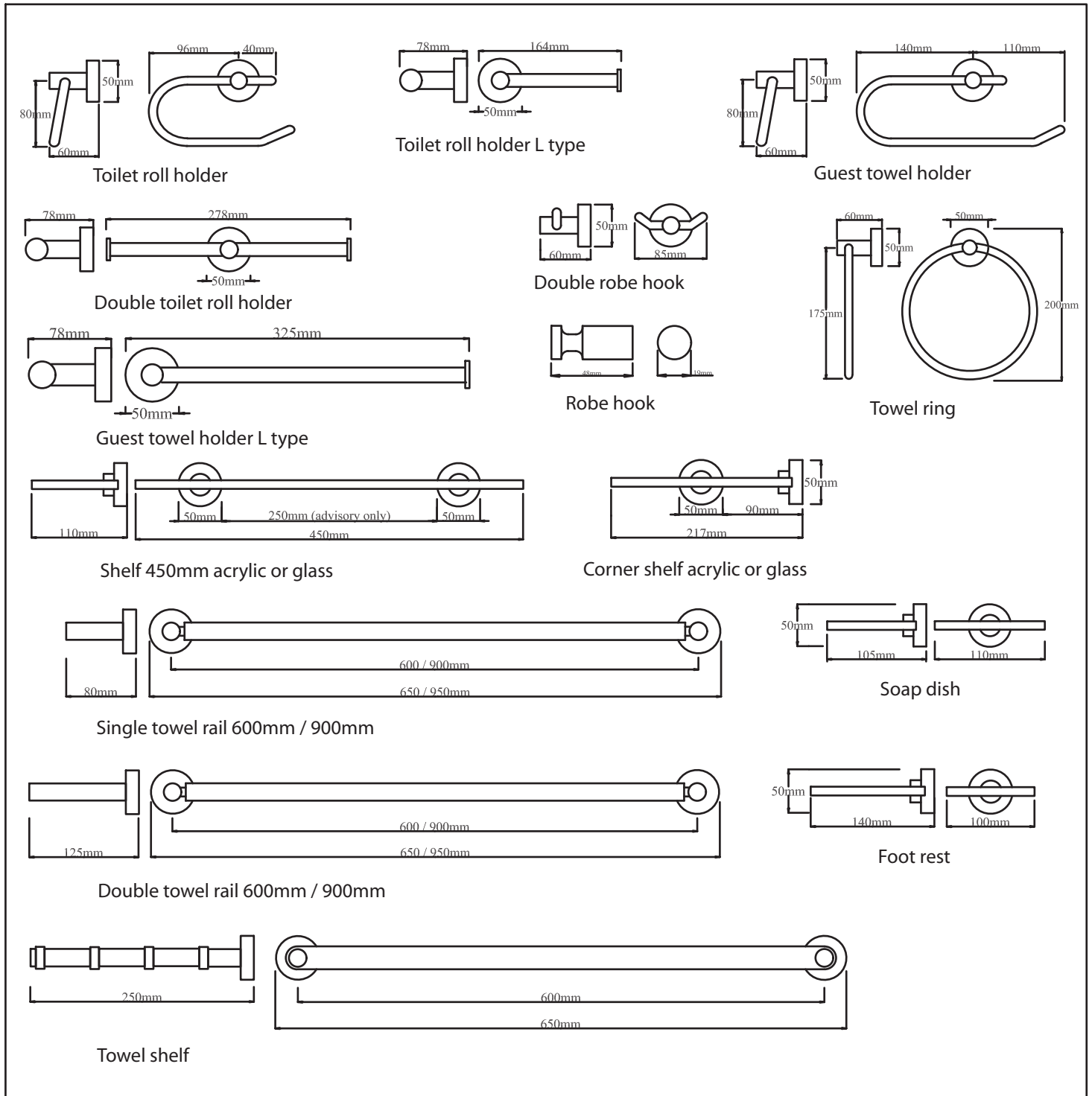

All select accessories feature:

- ◆ Sleek functional design
- ◆ Stainless steel concealed fixings
- ◆ Solid brass chrome plated construction
- ◆ Custom sizes available on request
- ◆ Full factory guarantee of 10 years